



GIN

BOBCAT owner's manual – English



Thank you for taking the time to read this manual before using the BOBCAT.

Thank you...

Thank you for choosing the BOBCAT. We are confident that this speedflying glider will provide you with countless exciting and fun experiences and will enable you to make good progression in your speedflying career. This manual contains all the information you need to fly and maintain your glider. A thorough knowledge of your equipment will keep you safe while enabling you to maximise your full potential.

Please pass on this manual to the new owner if you ever resell your glider.

Have fun!

The GIN Team

Safety Notice

By the purchase of this equipment, you accept all risks inherent with speedflying activities, including injury or death. Improper use or misuse of GIN equipment greatly increases these risks. Neither GIN gliders Inc nor the seller of GIN equipment shall be held liable for personal or third party injuries or damages under any circumstances. The user is fully and solely responsible for the safe use of this equipment, if there is any doubt regarding the use or safety of this equipment then it should not be used.

Warning: Speedflying is a potentially dangerous activity. It is the user's own responsibility to assess all weather and meteorological conditions, the flying area, all equipment, etc, before you use this equipment. This equipment was not designed for any other use than that of speedflying as described in this manual. This equipment should be launched from the ground and must never be used for any of the following: Parachuting, BASE jumping; jumping from any aircraft, or high object; building, antenna, bridge, cliff, etc. You should wear a helmet as well as all safety equipment required for the practice of paragliding and Speedflying. It is strongly recommended to learn Speedflying in a specialised school. When Speedflying, always choose a safe, open area enabling you to keep a wide safety margin. Do not practice Speedflying in the vicinity of obstacles, cliffs, rocks or any other hazards. This equipment requires constant care when it comes to maintenance and handling. Only use the Bobcat glider with the Bobcat harness; they have been designed to be used together.

Contents

Thank You.....	2
Safety Notice.....	2
1. Gin Gliders	4
2. Introducing Speedflying.....	5
3. Introducing the BOBCAT.....	5
Speedflying field of use.....	5
For Pilots Who.....	6
Manufacturing	6
4. Before you Fly.....	7
Pre-delivery Inspection	7
Trim Risers	7
Brake line adjustment.....	8
Rucksack.....	8
Your harness	8
Certified weight range.....	9
Essential	9
5. Flying the BOBCAT	10
Preparation for launch.....	10
Take off	10
Min Sink / best glide	11
Accelerated flight	11
Active flying.....	11
In turbulence.....	11
Steering without brakes	11
Landing with the BOBCAT	12
6. Care, maintenance and repairs.....	13
Ground handling	13
UV damage	13
Packing instructions	13
Transport and storage	14
Cleaning	14
Inspections.....	14
Repairs.....	14
7. Reference.....	15
Technical specifications.....	16
Line plan	16
Description	17

1. Gin Gliders

Gin Gliders was formed in 1998 by paraglider designer and competition pilot Gin Seok Song and his team of engineers and test pilots.

Gin's philosophy is simple: To design gliders that he, and any other pilot, will love to fly. This philosophy applies equally for a speedflying glider such as the BOBCAT, as for the world beating competition glider, the Boomerang. No glider is released on the market without Gin's complete satisfaction.

Gin has over 20 years experience of designing and manufacturing free flight equipment, and is backed up by an equally experienced team, both within the company in Korea and throughout a worldwide network of distributors and dealers.

This high level of expertise provided by dedicated professionals ensures that you get the best possible product support and after sales service.



2. Introducing Speed Flying

Speedflying, a new flying concept.

A new flying craze is here: Speedflying; flying fast downhill.

Over the last few years, Gin Gliders have been developing speedgliders for speedriding (launch by ski).

Now, Gin Gliders introduces a speedglider designed for foot launch, the Bobcat.

Speedgliders, a new design concept.

Speedriding and speedflying are both based on a new design concept developed by Gin Gliders.

Speedgliders are not small paragliders, like for example the « Yeti 19 » which is a mini-paraglider and part of our paraglider range.

Speedgliders are dedicated to fly with low glide ratio, stability and speed.

The Speedgliders' concept is based on :

- Pitch Stability
- Angle of attack control
- Variable glide ratio
- Speed control

3. Introducing the BOBCAT, the Speedflying wing

The Bobcat is opening new horizons of piloting for expert and careful pilots with a lot of flying experience.

The air, the speed and the fun are joined for a new dimension of flight... the possibilities are growing!

The play of trajectories and speed against the relief opens new piloting potential, as yet unexplored using soft canopies.

The Bobcat will give you the possibility to return to the original soul of flight and also to open up new fields of practice. You will be able to fly down the mountain in wider aerological conditions with this simple and solid glider. You will have fun with strong wind ground handling and soaring...

Speedflying fields of use...

"Traditional" Speedflying

Unlike modern paragliders, the Bobcat will give you an adrenaline-powered ride down a mountain, following the slopes and ridges. This is due to a lower glide ratio and higher trim

speed. You'll reach the bottom faster, but with a huge grin on your face.

Soaring in stronger winds

How many pilots confronted with "strong" winds of 30-45 km/h, have dreamed of the Bobcat? Here it is!

On the coast, in the mountains, or on your favourite hill, when it is impossible to take your paraglider from its bag, the Bobcat is ready to take over.

Ground training

How many paragliding schools have dreamed of the Bobcat? Here it is.

To learn in safety on school slopes the basis of inflation and to become familiar with techniques for stronger winds, the Bobcat is a wonderful educational tool.

Mountaineering

How many mountaineers climbing down from a summit have dreamed of the Bobcat? Here it is!

The Bobcat will allow you to take off and fly in stronger winds than would be possible with a paraglider. The Bobcat is compact, light and will easily fit into the bottom of an experienced mountaineer's backpack. Its instantaneous inflation and its high stability in turbulence will allow you to experience mountains in a thrilling new way.

For pilots who...

The Bobcat is a speedglider designed for highly experienced and responsible pilots that have enough knowledge to adapt to the speedglider's dynamic handling. The higher wing loading increases the speed and the responsiveness of the handling. The glide angles are much lower than with modern paragliders. The landing approach and landing itself are considerably different.

The Bobcat is not recommended for busy flying sites and training in a professional paragliding school is strongly recommended. Regular practice on the ground is very useful. Take special care when deciding when and where to fly, and respect other flyers and flying machines.

Manufacturing

All GIN gliders are produced in the company's own facilities using the most modern techniques. Highly skilled staff take extreme care throughout the entire manufacturing process. Stringent quality control is made after each step, and all materials that go into each wing can be traced. These measures guarantee that pilots fly with the assurance that their wing meets the most exacting safety standards.

4. Before you fly

Pre-delivery Inspection

The BOBCAT is delivered with a rucksack, the Bobcat harness (designed specifically for the Bobcat), inner bag, compression strap, repair tape and this manual. Your instructor or dealer should have made a test inflation followed by a test flight before delivery.

Risers and trimmers

The back risers of the BOBCAT are fitted with trimmers that enable the pilot to adapt the glider's behaviour to match his level and the chosen slope. Trimming down (shortening) the back risers makes the glider slower, the handling less responsive and more forgiving, so suitable for pilots that have less experience. Trimming up the risers accelerates the glider, see accelerated flight for more details. Ask for the advice of an instructor who specialises in Speedflying in order to better understand and exploit the trimming system.

#13.5, #15, #16,5	A	C	D
Turn Down	50cm	49cm	48cm
Neutral	50cm	50cm	50cm
Turn up	50cm	53cm	56cm

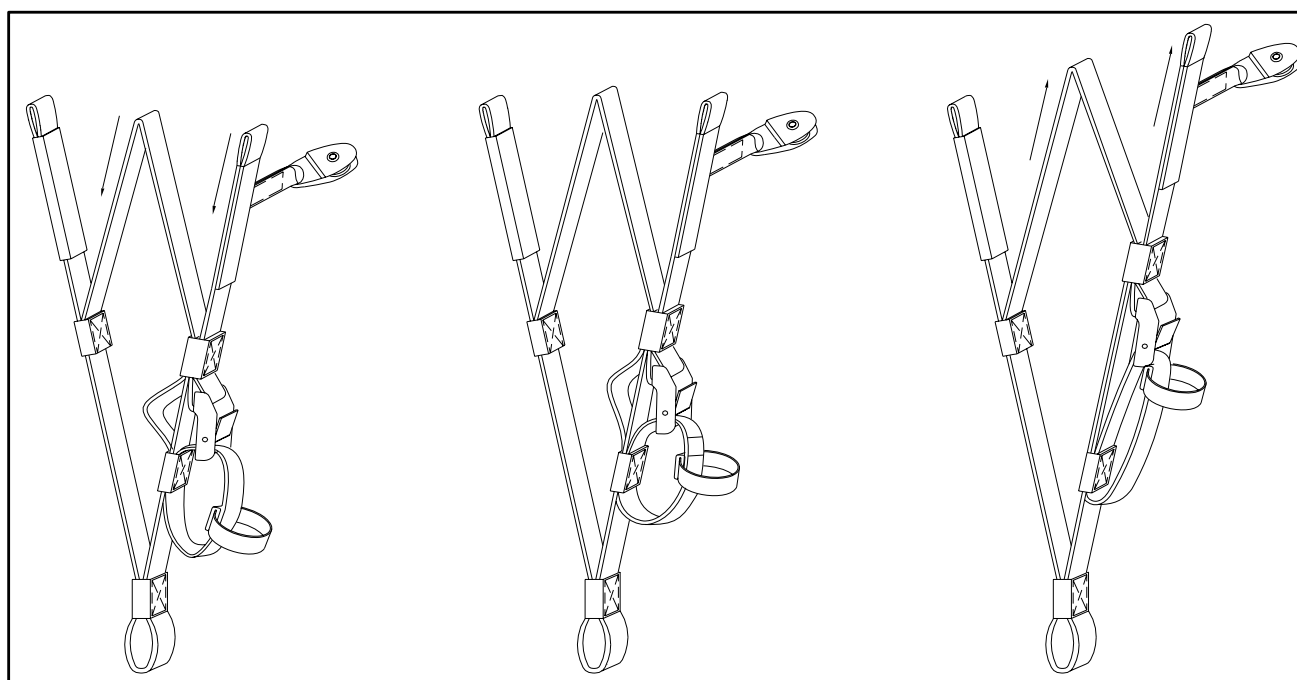

Trim down

Neutral

Trim up

Brake line adjustment

The main brake line lengths of the BOBCAT are the same as on the sample that has been used by the GIN R&D team. These line lengths have been fine tuned by GIN test pilots, and it should not be necessary to adjust them.

In soaring flight, it is common to fly with half a wrap on the brakes and hold the handles on the knot. However, care should be taken to release the wraps in any extreme situation.

If you do need to make adjustments to suit your harness, body and flying style, we strongly recommend that you test fly the glider with every 2cm of adjustment. There should be a minimum of 10cm of free brake travel when the glider is flown hands-off. We recommend a double sheepshank or a bowline knot for the brake handle attachment as shown in the diagram.

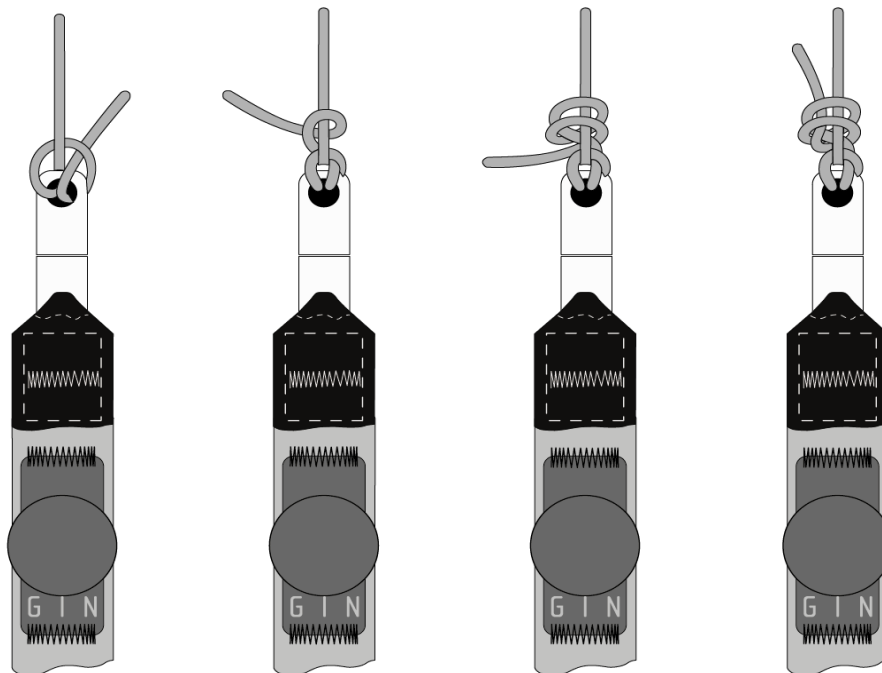

Rucksack

The BOBCAT is delivered with a rucksack and a harness specifically designed for carrying comfort and ease of use.

Your harness

The BOBCAT was developed with the BOBCAT harness, specific to Speedflying. We recommend that you use the BOBCAT solely with this harness.

Adjusting the chest strap controls the distance between the carabiners of the two risers, which has an influence on the glider's behaviour.

There is no need to use the BOBCAT with a tight chest strap adjustment, as there is no tendency to feel unstable.

Weight range

The BOBCAT should be used in the weight range for which it was designed. The weight range is defined according to the pilot's weight, including clothes.

BOBCAT	#13,5	#15	#16,5
Weight/ piloting level	expert	Advanced $\leq 80\text{kg}$	Advanced $80\text{ kg} \geq$

Essential

In order to fly with this equipment, you should:

- *Have received theoretical and practical tuition for Speedflying.
- *Have sufficient practice, the knowledge and the experience necessary to use this glider correctly and safely.
- *Have subscribed to the licences and insurances necessary for the practice of this sport.
- *Be in normal physical and mental health, not be under the influence of alcohol or other drugs.
- *Fly only in meteorological conditions fit for the practice of Speedflying (and adapted to your level and experience).
- *Wear a helmet and all safety equipment necessary to the practice of speedflying.
- *Have thoroughly checked all your equipment.
- *Be aware of all the information contained in this manual.

5. Flying with the BOBCAT

We recommend that you first practice inflating your glider on a small training slope. Make your first flights with your new speedflying glider in gentle conditions in a familiar area.

Preparation for launch

Following a consistent method of preparation and pre-flight checks is vital for safe flying. We recommend the following:

On arrival at the flying site, assess the suitability of the conditions: wind speed and direction, airspace.

Inspect your glider, harness, helmet and any other equipment.

Choose a sufficiently large take-off area with even ground and no obstacles.

Lay the glider out according to the planform, and get the lines and risers sorted out.

Put your helmet on. Secure yourself in your harness and don't forget the leg loops!

Connect the risers to your harness carabiners, ensuring there are no twists or loops around the lines.

Do a final line check by pulling gently on the risers or lines to ensure there are no new knots, tangles or interfering branches or rocks. Take extra care in nil or light winds.

Pre-flight check list

Helmet and harness buckles closed.

Lines free.

Canopy open and into wind.

Airspace clear.

Take off

The key to a successful launch technique is to practice ground handling whenever you can.

Keeping your brake handles in your hands, the **BOBCAT** inflates very easily, with front risers in hand. Keep your arms slightly bent and hands at shoulder height. While using the front risers, your arms should rise in a curve. **It is not necessary to pull hard on the risers.**

Make a visual check on your glider before taking off to see if it is correctly inflated and that there are no knots or tangles. If something is wrong, abort the take off.

A slight pressure on the brakes always makes the take off easier. Don't forget to run fast with long strides!

Trim position for take off at normal altitude in normal conditions is : "neutral"

Minimum sink rate and max glide ratio.

The minimum sink rate can be found by pulling the brakes on by about 20 cm. the theoretical max glide ratio is obtained by trimming the back risers by 1 cm.

Accelerated flight

Once you have become accustomed to flying the **BOBCAT**, you can practice using the trimmers. These enable you to increase the speed of your glider, and to have better penetration through the air in stronger wind conditions. Expert pilots can also use the trimmers to better match their glide to the angle of the slope. Caution: when flying accelerated, your wing will react in a quicker, more responsive manner in turns and the glide angle will be a lot steeper. Learn and take advice from a qualified instructor.

Active Flying

The **BOBCAT** has a high internal pressure, high resistance to collapses and a high level of passive security. However, due to the small area and short lines length, it is recommended with this type of glider to adopt an active handling style that will help you to fly safely. The key to active handling is to keep your glider above your head. If the glider has a tendency to lag behind, raise your hands. If the glider has a tendency to shoot forward, then control it with the brakes. In all cases, always remember to keep sufficient air-speed and avoid over-piloting. Be ready to control the roll axis also, piloting the exit of spiral if needed.

In turbulent conditions

The **BOBCAT** is a very stable glider and collapses on one or both of the front risers are extremely rare. Extreme turbulence could generate a collapse but the **BOBCAT** will resume normal flight in almost all configurations. In case of any doubt, keep your hands at shoulder height and let the glider fly.

However, if the glider shoots forward violently, control it with the brakes immediately. To help your glider resume flight more rapidly, it is recommended to use an active handling style, without being out of time with the wing's movements.

Steering without brakes

If a brake is not operational for some reason, you can steer the **BOBCAT** with the C-risers. Add steering input by weight-shifting in your harness. Be careful not to steer too much with the riser to avoid any possibility of a spin.

Caution :

The BOBCAT is not designed to perform manoeuvres outside the normal flight configuration. Our test pilots have tested the various reactions in extreme situations; however we strongly recommend that you do not perform stalls, manoeuvres and spins. It is also strongly recommended not to fly any aerobatics with the **BOBCAT**.

Landing with the BOBCAT

Choose a landing area free of obstacles. It is recommended to land with a full flair; it will enable you to obtain a zero vertical speed and an easy run at the end of the flair. Do not make your last turn at low height, or make a radical turn close to the ground. Do not approach too slowly with the back trimmer on and a lot of brake. The best landing approach is with the trimmers set to neutral and then use a proper flair to bleed of your speed.

You can land in full speed trim position, low speed position or ether at neutral position, as you manage your flair correctly.

6. Care, Maintenance and Repairs

The materials used in the BOBCAT have been carefully selected for maximum durability. Nevertheless, following the guidelines below will help keep your glider airworthy and will ensure a long period of continuous safe operation. Excessive wear is caused by careless ground handling and packing, unnecessary exposure to UV light, chemicals, heat and moisture.

Ground handling

Be careful of the following:

- Violent shocks to the upper surface (e.g. when the canopy crashes to the ground leading edge first whilst ground handling).
- Dragging the glider along the ground.
- Dyneema, the core material of the lines, is very strong and can take high loads without stretching, but it is sensitive to heat.
- Opening your wing in strong winds without first untangling the lines.

UV damage

Avoid leaving the glider out in the sun unnecessarily. UV rays from the sun degrade glider cloth.

Packing instructions

We advise you to pack the glider "accordion wise" as shown in the drawing. This packing procedure takes slightly longer and is easier to do with an assistant, but it conserves the rigidity in the profile reinforcements.

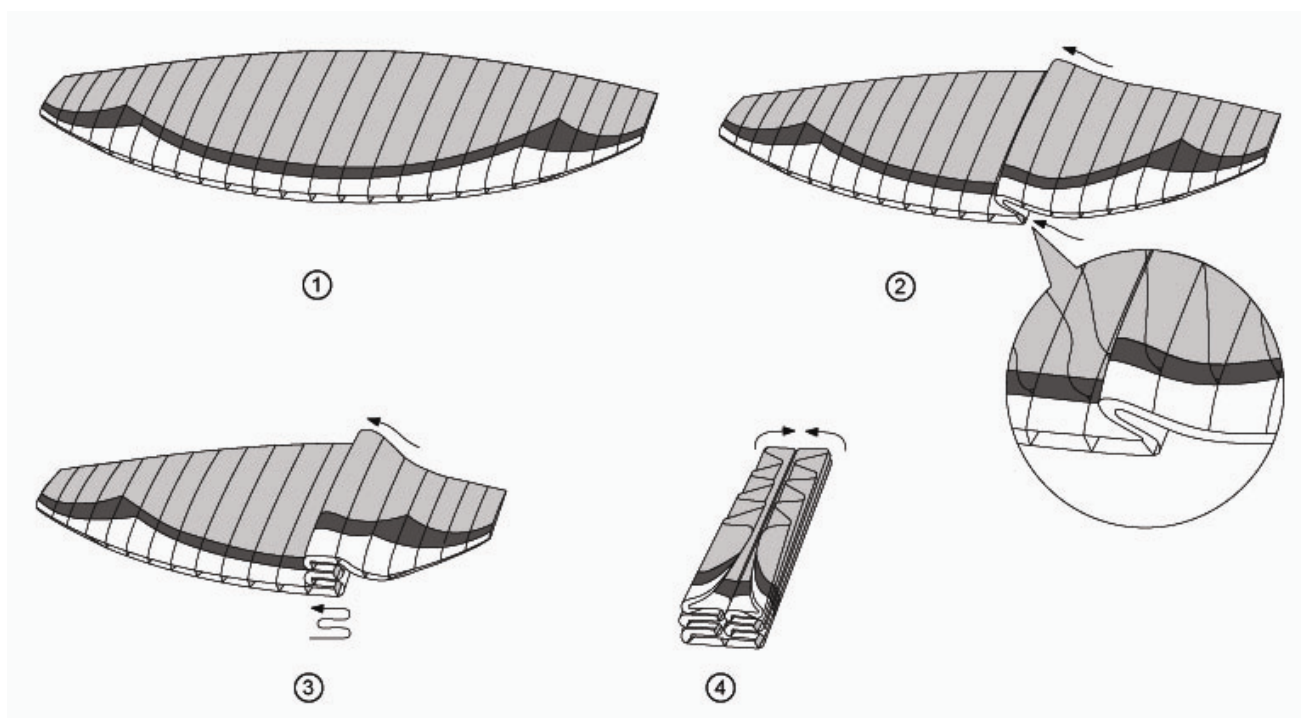

Since folding the glider weakens the materials, pack the glider as loosely as possible.

Transport and Storage

Moisture is the worst enemy of your glider, adversely affecting the ageing of fabric, lines and reinforcements. The BOBCAT should therefore be kept dry and cool. Do not pack the glider away for a prolonged period if it is damp, sandy, salty, or if other objects have entered the cells. Always allow it to dry naturally before storage in a dry room. Leave the rucksack zip open whenever possible to allow residual moisture to evaporate, and do not transport or store the glider in the proximity of chemicals such as gasoline, paints or other solvents.

Cleaning

Use only lukewarm water and a soft cloth to clean your wing. Never use any abrasive materials or detergents. Only clean the wing if it is absolutely necessary e.g. after a landing in salt water.

Maintenance Inspections

GIN Gliders recommend that the BOBCAT is inspected by an authorized Gin agent after every 100 hours flying time or every year, whichever is sooner.

The maintenance instructions, which can be downloaded from our homepage www.gingliders.com, have to be observed.

A full inspection will give you peace of mind and extend your glider's lifetime. Additional inspections should be performed by a qualified person following a crash or violent landing on the leading edge, or if you note a deterioration of performance or behaviour.

You should also check for any damage to your lines, sail, risers and connectors before each flight.

Repairs

Very small holes in the sail can be repaired with the sticky-backed ripstop tape provided with your glider. Damaged lines should be replaced by your GIN dealer. Before fitting a replacement line, check it for length against its counterpart on the other side of the wing. When a line has been replaced, always inflate the glider on flat ground to check that everything is in order before flying.

Major repairs, such as replacing panels, should only be carried out by the distributor or manufacturer.

7. Technical data BOBCAT

Technical data BOBCAT

SIZE		13.5	15	16.5
FLAT	AREA	13.5m ²	15m ²	16.5m ²
	SPAN	7.25m	7.65m	8.0m
	A.R	3.9	3.9	3.9
PROJECTED	AREA	11.42m ²	12.69m ²	13.96m ²
	SPAN	5.8m	6.12m	6.42m
	A.R	2.95	2.95	2.95
CHORD	ROOT	2.18m	2.30m	2.41m
	TIP	0.91m	0.96m	1.01m
CELL NUMBER		26	26	26
GLIDER WEIGHT		3.2 kg	3.5 kg	3.8 kg

Line Plan

Line material	
Upper line	TGL140, TGL80
Main line	TGL280
STB Main	TGL140
Brake Main	TGL200

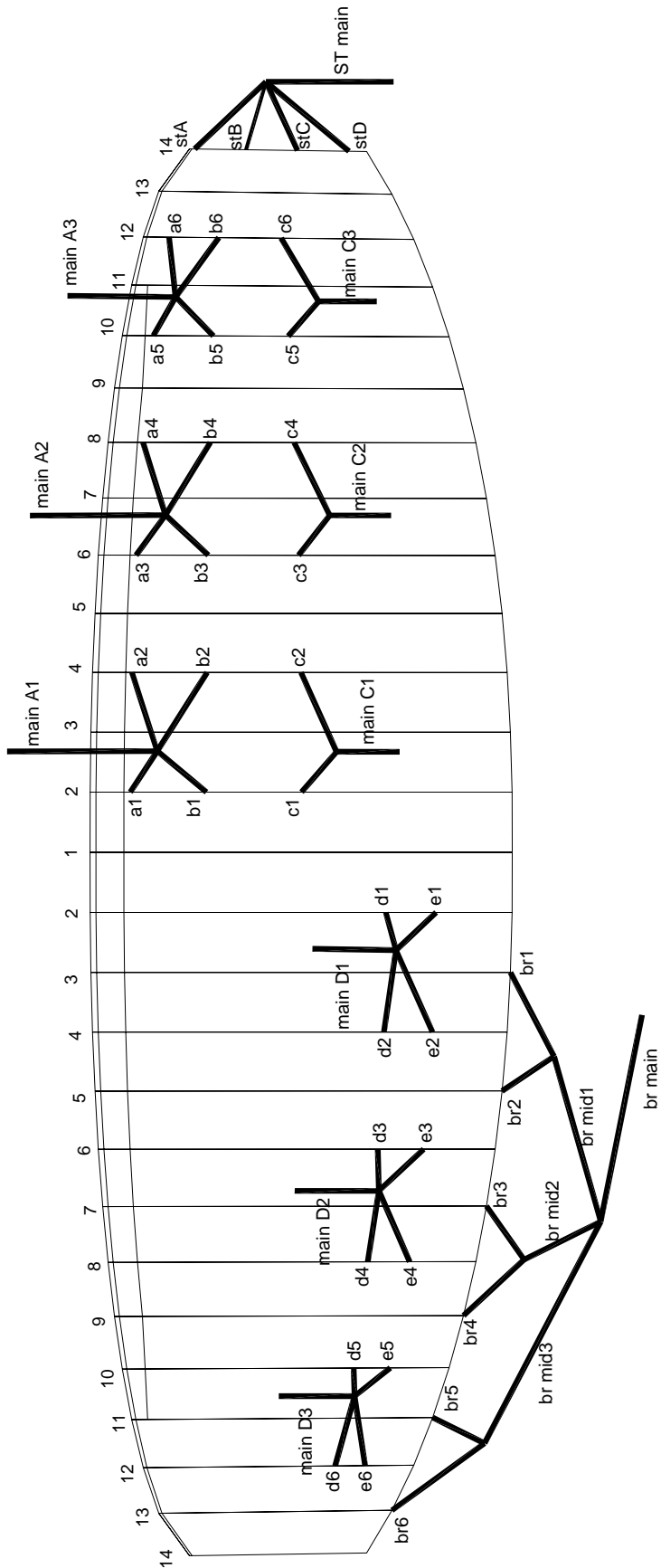

Description

FABRIC OF CANOPY

SUPPLIER	NAME	DOMINICO TEX	
	ADDRESS	641-11 Dungchondong Kangseogu Seoul Korea	
TYPE OF FINISH		SIDE COATED	
TYPE OF YARN		NYLON 6.6 HIGH TENACITY – 30 Denier	NYLON 6.6 HIGH TENACITY – 30 Denier
FABRIC CODE		3RS ME (Top and Bottom surface)	3RS FM (Rib)
PATTERN		Rip Stop	Rip Stop
Coated fabric's weight (g/sqm)		43+2	43+2
Tear Strength	WARP (DaN)	3.6 Max	3.6 Max
	WEFT (DaN)	4.1 Max	4.1 Max
Elongation on bias 3 lbs (%)		11.5 Max	11.5 Max
Elongation on bias 5 lbs (%)		17.5 Max	17.5 Max
Elongation on bias 10 lbs (%)		25.5 Max	25.5 Max
Break Strength	WARP (DaN/5cm)	42 Max	42 Max
	WEFT (DaN/5cm)	43 Max	43 Max
AIR Permeability p=2000Pa (I/SQMXMN)		40 Max	40 Max

Suspension line

MATERIAL		ARAMID(TECHNORA)		
SUPPLIER	NAME	TEIJIN LIMITED, JAPAN		
	ADDRESS	1- 1, UCHISAIWAI-CHO 2-CHOME, CHIYODA-KU, 2- TOKYO 100, JAPAN		
DIAMETER(mm)		TGL80(Top)	TGL140(Top)	TGL280(Main)
DIAMETER(mm)		1.1	1.4	1.8
YARN COUNT		1,000D	1,000D	1,000D
NUMBER OF CORE		4	7	14
BREAKING STRENGTH		80kg	140KG	280kg

Reinforcement

FABRIC CODE		W420 SCRIM		
SUPPLIER	NAME	PORCHER NCV Industries		
	ADDRESS	L'Isle d'Abeau, Parc de Chesnes, 75, rue du Ruisseau 38070 SAINT QUENTIN FALLAVIER Cedex / France		
MATERIAL		POLYETER SCRIM		
WEIGHT(GR/M ²)		180		
BREAKING STRENGTH (KG/5Cm)	WARP	137		
	WEFT	118		
TEAR STRENGTH (KG/5Cm)	WARP	4.2		
	WEFT	4.1		
WEAVE DESIGN		RIPSTOP		

Riser

MATERIAL		POLYESTER TAPE
SUPPLIER	NAME	Güth & Wolf GmbH
	ADDRESS	Herzebrockerstr. 1-3 D-33330 Gütersloh GERMANY
WEIGHT(GR/M)		34
BREAKING STRENGTH		1,100DAN
WIDTH(mm)		20mm

Maillon

MATERIAL		STAINLESS STEEL
SUPPLIER	NAME	SUBO TECH CO.
	ADDRESS	981-1 CHAGOK-RI PALTAN-GU, HWASUNG-CITY, KYUNG KI-DO, KOREA
WEIGHT(GR)		12
BREAKING STRENGTH		1,000kg
DIAMETER(mm)		4.3

Bridle (Attachement line)

MATERIAL		NYLON
SUPPLIER	NAME	SUPPLIER
	ADDRESS	45 MU KYO DONG JUNG – GU, SEOUL, KOREA
WEIGHT(GR/M)		7.2
BREAKING STRENGTH (kg)		110
WIDTH(mm)		13

Thread

MATERIAL		HIGH TENACITY POLYESTER YARN	
SUPPLIER	NAME	AMANN & SOHNE GMBH & CO.	
	ADDRESS	INDUSTRIESTRASE 1, D-74391 ERLIGHEIM, GERMANY	
DENIER		150D/2	250D/3
BREAKING STRENGTH		2.9kg	3.2kg
WEIGHT(GR/M)		0.05G	0.083G

"Designing gliders is a personal journey of challenge and discovery, an ongoing search for perfection."

- Gin Seok Song

Every effort has been made to provide you with important and useful information in this flight manual. However, please remember that this is not a book made to teach you how to fly, and that courses in a certified professional school are necessary for the safe practice of Speedflying.

This flight manual may be amended at any time without any prior notice. Please visit our website www.gingliders.com for all the latest information regarding the BOBCAT and all GIN gliders' products.